

PLAN VIEW WITH COVER

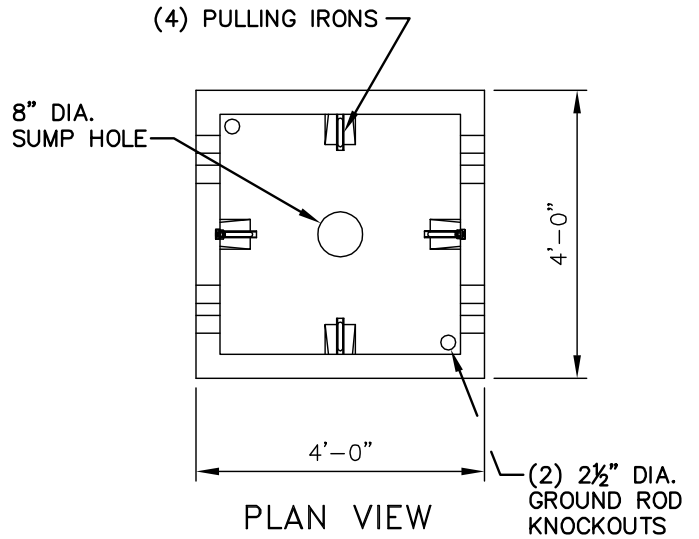

PLAN VIEW

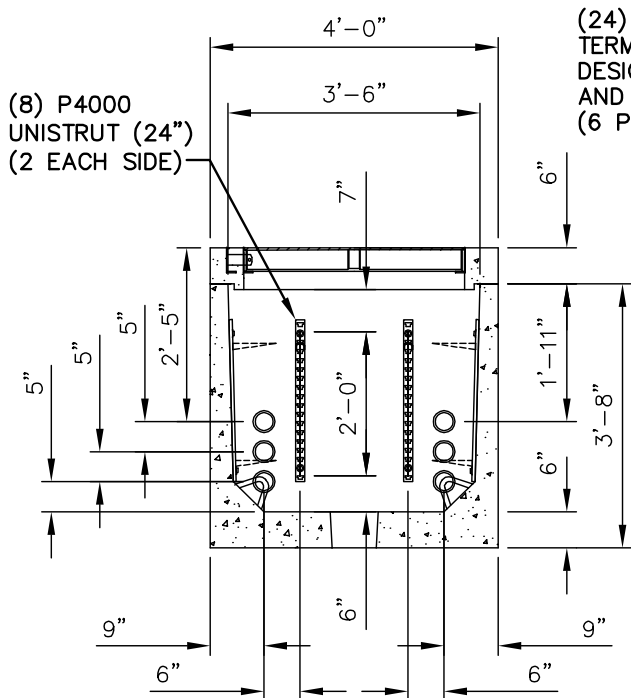

SECTION VIEW

(24) 4" SCHEDULE 40 TERM- A-DUCTS, 2 STEP DESIGN FOR 4.35" DIA. AND 4½" DIA. PVC PIPE (6 PER SIDE/4 SIDES)

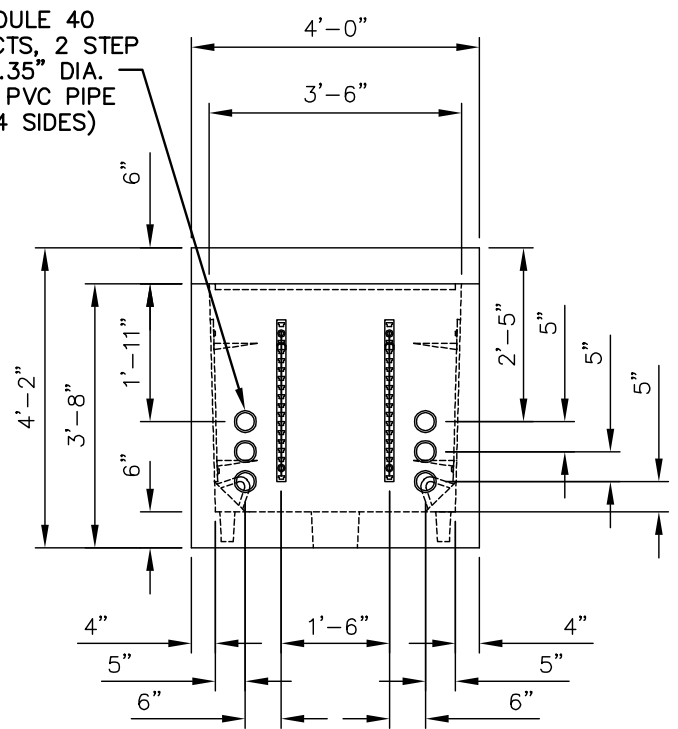

END VIEW

NOTE:
SEE SHEET 2 FOR GENERAL NOTES, STRUCTURAL NOTES AND RACKING PACKAGE DETAIL.

SIGNATURES
ON FILE





CITY OF GLENDALE
TRAFFIC SIGNAL AND ITS STANDARDS

NO. 9 PULL BOX

REVISION:
2/2008

T2-9
1 OF 2

RACKING PACKAGE DETAIL

-  8 - 18 HOLE RACK
-  16 - 1/2" SPRING NUTS AND BOLT
-  16 - 7/2" STRAIGHT HOOKS

PLAN SYMBOL

-  EXISTING
-  NEW

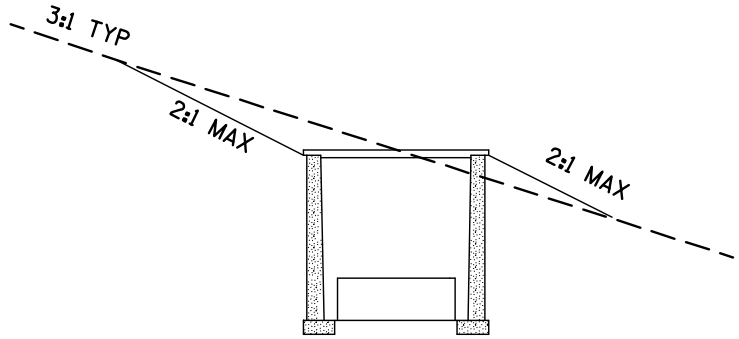

INSTALLATION IN SLOPED AREAS

GENERAL NOTES:

1. BACKFILL WITH DESIGNATED SIZE NO. 57 AGGREGATE BELOW PULL BOX. BACKFILL AROUND SIDES OF PULL BOX WITH SELECT EXCAVATED MATERIAL AND THOROUGHLY COMPACT.
2. CONDUIT FROM THE TYPICAL TRENCH SECTION SHALL NOT DEFLECT BY MORE THAN 1"/12" FROM THE ALIGNMENT PRECEDING OR FOLLOWING THE PULL BOX.
3. TOP OF CONDUITS SHALL BE LOCATED AT 25" BELOW EXISTING GROUND. CONDUITS AT PULL BOXES SHALL DEFLECT NO MORE THAN 1"/12" TO ENTER PULL BOX. CONDUITS SHALL BE FLUSH WITH INSIDE OF PULL BOX.
4. LONGITUDINAL AND LATERAL CONDUITS ENTER AND EXIT SAME WALL. LATERAL CONDUITS AS REQUIRED.
5. ALL NEW PULL BOXES SHALL BE FURNISHED WITH RACKS AND HOOKS INSTALLED.
6. PLUG EACH UNUSED CONDUIT END WITH APPROVED, WATERPROOF DUCT PLUG.
7. "COG COMMUNICATIONS" SHALL BE THE TITLE EMBOSSED ON THE LID.
8. PULL BOX HEIGHT SHALL BE FINISHED GRADE TO MATCH EXISTING GRADE/SLOPE.
9. LID SHALL OPEN 180 DEGREES WITH A TORSION BAR LIFT ASSIST.
10. LID SHALL BE DIAMOND PLATE AND HAVE GALVANIZED FINISH.
11. BOX SHALL BE ORIENTED SO THAT LID OPENS AWAY FROM ANY ROADWAY LANE.
12. COVER HARDWARE SHALL BE CADMIUM PLATED.
13. RECESSED PADLOCK MAYBE LOCATED ON EITHER SIDE OR ON THE OPENING SIDE OF THE COVER.
14. PULLING IRONS SHALL BE LOCATED AS SHOWN IN PLAN VIEW, NO DEVIATIONS ACCEPTED.
15. PULLING IRONS SHALL BE 3/4" O COLD ROLLED GALVANIZED STEEL.
16. WEIGHT COVER = 1075#, VAULT 3250# - 4250#, TOTAL 4325# - 5325#.
17. GROUT OR SEAL SHALL BE USED AROUND CONDUITS PENETRATING THE PULL BOX.
18. ALL JOINTS SHALL BE SEALED USING CONSEAL CS-101 BUTYL RUBBER ROPE.

STRUCTURAL NOTES:

1. CONCRETE: 28 DAY COMPRESSIVE STRENGTH $f'_c = 4500$ PSI
2. REBAR ASTM A-615 GRADE 60
3. MESH: ASTM A-185 GRADE 65
4. DESIGN: ACI-318-99 BUILDING CODE AND ASTM C-857 "MINIMUM STRUCTURAL DESIGN LOADING FOR UNDERGROUND PRECAST CONCRETE LOADING STRUCTURES"
5. LOADS: HS20 WHEEL LOADING IN OFF-STREET LOCATIONS WHERE NOTE SUBJECTED TO HIGH DENSITY TRAFFIC
 - 80 PSF LATERAL LIVE LOAD SURCHARGE - UP TO 8'-0" DEPTH
 - SOIL: 40 PCF LATERAL SOIL PRESSURE ABOVE WATER TABLE
 - 80 PCF LATERAL SOIL PRESSURE BELOW WATER TABLE
 - 120 PCF SOIL DENSITY
6. SOIL COVER: 0' TO 5' (MAX.)
7. WATER TABLE: 5'-0" BELOW GRADE

SIGNATURES
ON FILE



CITY OF GLENDALE
TRAFFIC SIGNAL AND ITS STANDARDS

NO. 9 PULL BOX

REVISION:
2/2008

T2-9
2 OF 2