

**BOLT SLOT DETAIL  
(TYPICAL)**

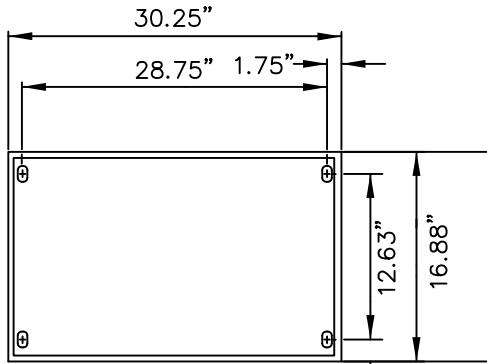

**SECTION A-A**

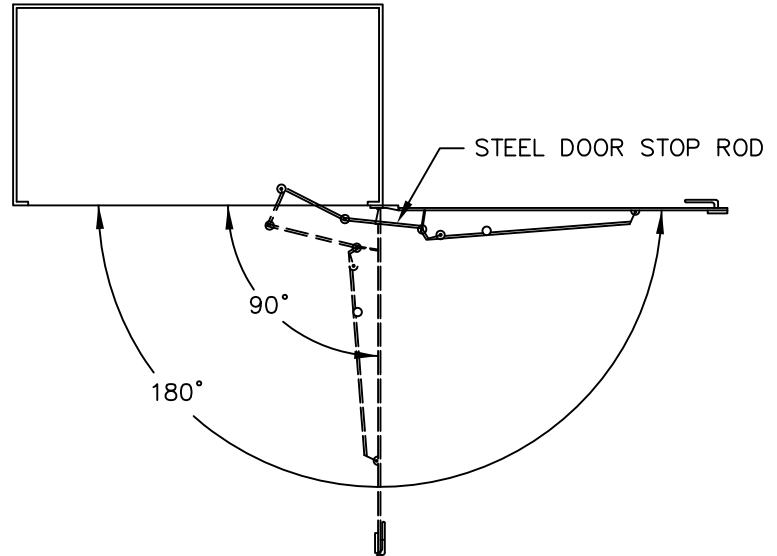

**2 POSITION DOOR STOP**

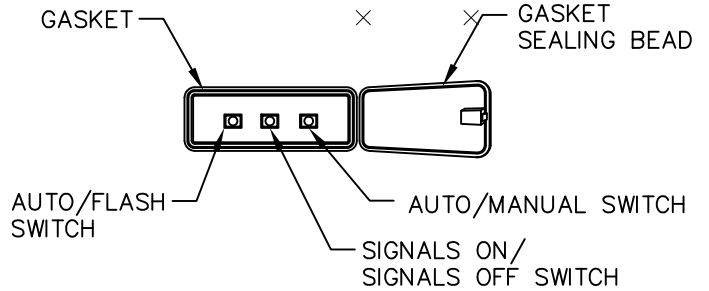

**POLICE PANEL**

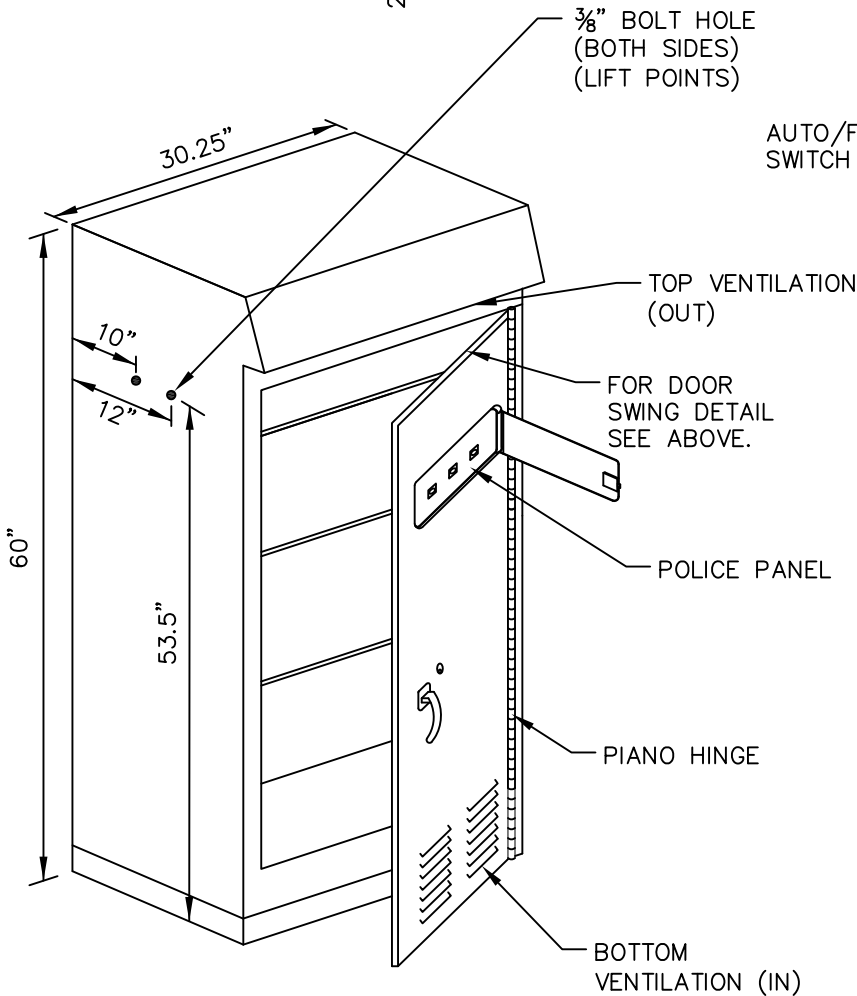

NOTES:

1. FOR CONSTRUCTION REQUIREMENTS SEE CITY SPECIFICATIONS.
2. THE DOOR SHALL BE RAIN TIGHT AND DUST PROOF.
3. THIS CABINET SHALL BE FURNISHED WITH FOUR 5/8" ANCHOR BOLTS, WITH TWO FLAT WASHERS AND ONE LOCK WASHER PER BOLT.
4. FOR CONCRETE FOUNDATION DETAIL SHEET T3-1.
5. SHELVES SHALL BE REMOVABLE AND ADJUSTABLE FOR VERTICAL SPACING. SHELVES SHALL BE SHEET METAL AS PER CITY OF GLENDALE SPECIFICATIONS.
6. CABINET SHALL BE INSTALLED SO THAT BACK WALL IS FLUSHED WITH CONCRETE FOUNDATION.
7. CONTRACTOR IS RESPONSIBLE TO MAKE SURE CABINETS FIT ON BOLT PATTERN.

APPROVED BY \_\_\_\_\_ DATE \_\_\_\_\_



CITY OF GLENDALE  
TRAFFIC SIGNAL AND ITS STANDARDS  
SIGNAL CONTROL CABINET SHELL SIZE 5A

REVISION: 12/2009
T4-2